

227
LINE



ART. 227

ART. 227

Apparecchio a funzionamento idraulico per operare su pesanti automezzi per lo smontaggio e montaggio di ruote semplici e gemellari, con comando sia a mano che a pedale. Completo di 4 ruote girevoli e doppi rulli a cuscinetti sui bracci di sollevamento. Bracci regolabili in senso trasversale.

Hydraulic functioning apparatus which operates on heavy vehicles to disassemble simple and twin wheels. It has a hand and foot-lever control. It is equipped with 4 turning wheels and double rolls with bearings on hoisting arms. The arms are adjustable in transversal directions.

Elévateur hydraulique à monter et démonter les roues simples ou jumelées des poids lourds, avec commande manuelle et à pédale. Equipé de 4 roues pivotantes et de double rouleaux sur les bras de levage. Bras réglables dans le sens transversal.

Hydraulik-Gerät für die Arbeit an schweren Fahrzeugen. Geeignet zur Demontage und Montage einzelner Reifen sowie Zwillingsreifen. Sowohl Hand-als auch Pedalbedienung. Ausgestattet mit lenkbaren Rädern und Tragarmen mit doppelten, kugelgelagerten Rollen. Durch einfaches Verstellen der Tragarme läßt sich das Gerät den verschiedenen Reifendurchmessern schnellstens anpassen.

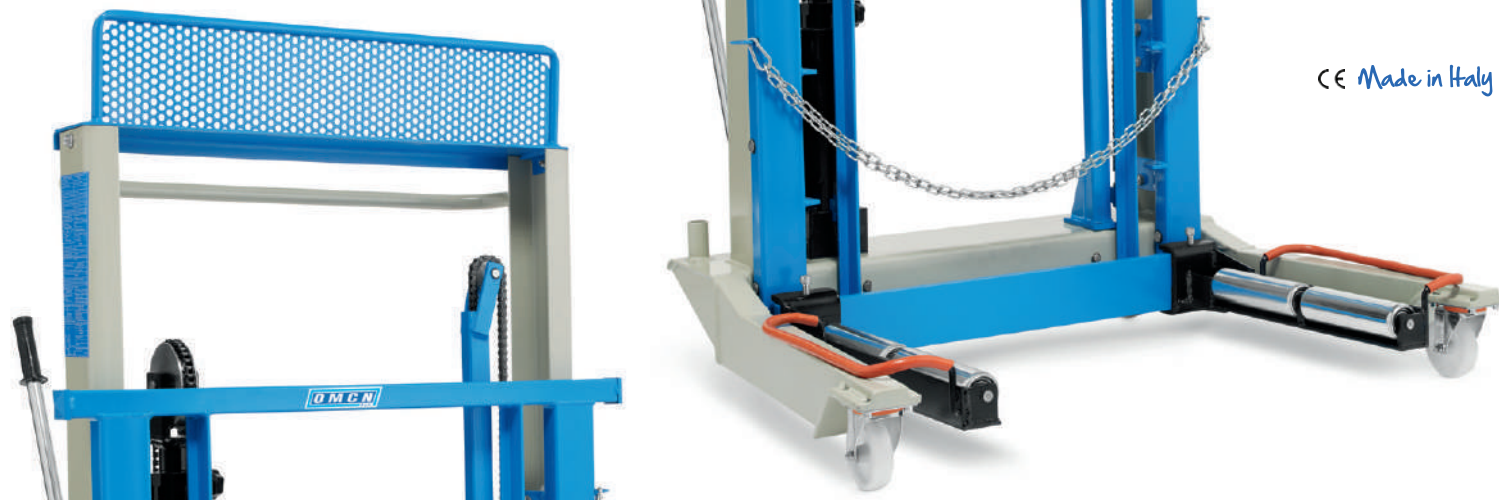

CE Made in Italy 

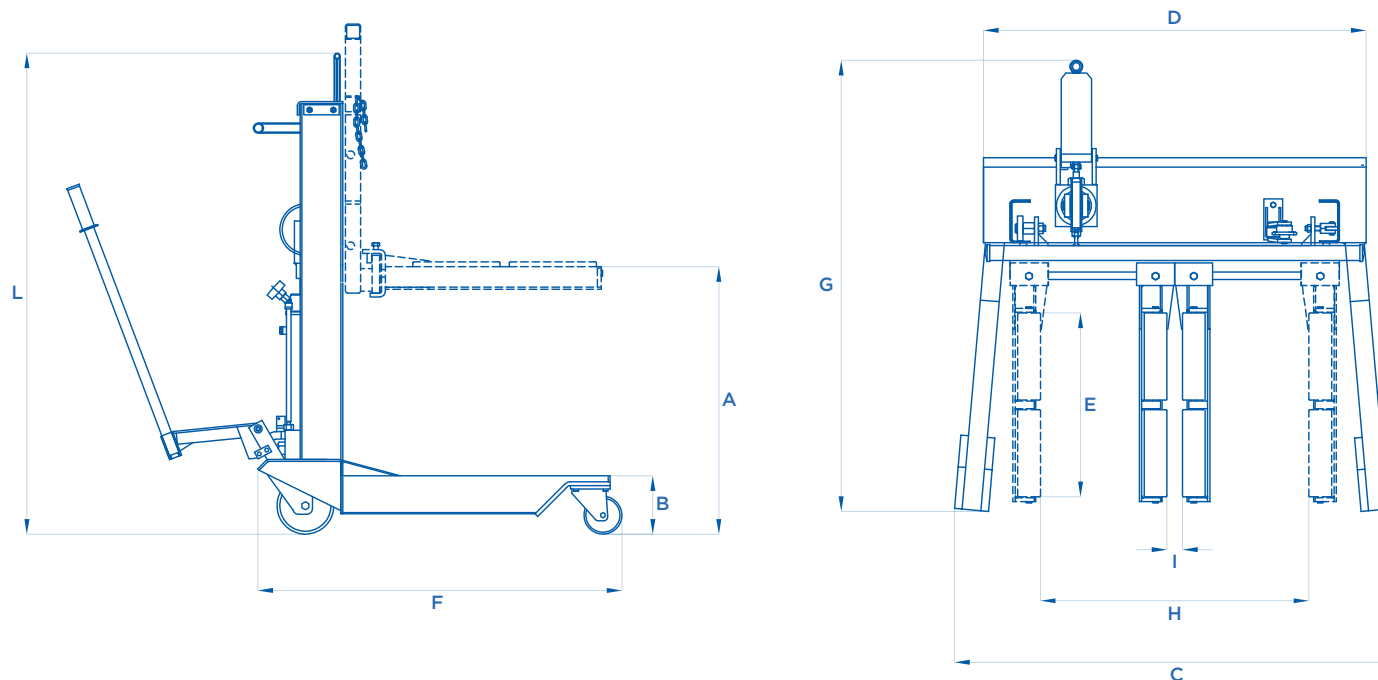

ART.		A 	B 	C 	D 	E 	F 	G 	H 	I 	L 
227	700 kg	650	160	1150	1000	490	920	1150	770	10	1410